

INSTALLATION DRAWING

DISEGNO DI INSTALLAZIONE

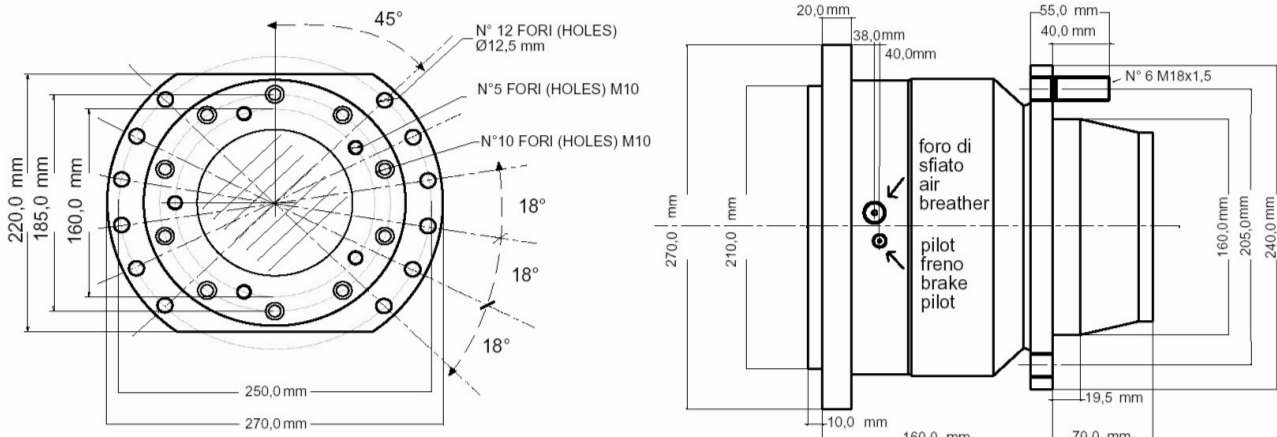

RADIAL LOAD

CARICO RADIALE

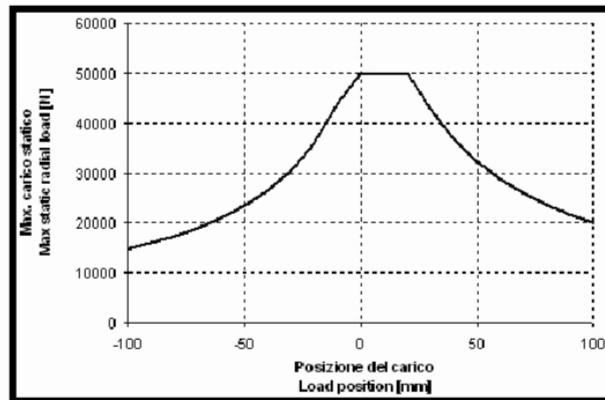

La posizione "0" coincide con la flangia ruota
Position "0" is coincident with wheel mounting

ORDER CODE

CODICE DI ORDINAZIONE

S070 / B - - /GM1 /

Wheel drive unit
Riduttore tipo

Motor mounting flange
Flangia motore

Braking system
Freno tipo

GM 05
GM1
BD1

00 without brake / *senza freno*
01 static brake / *con Freno statico negativo*