

**INSTALLATION DRAWING
(without Motor Flange)**

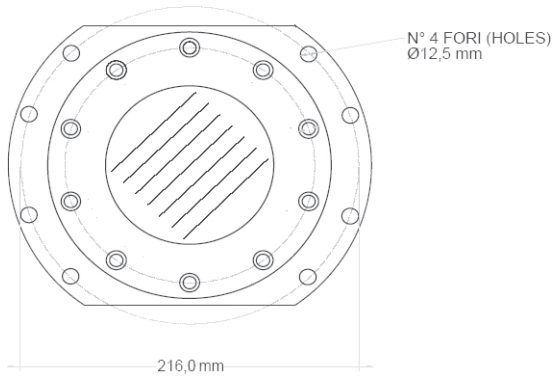

**DISEGNO DI INSTALLAZIONE
(senza Flangia Motore)**

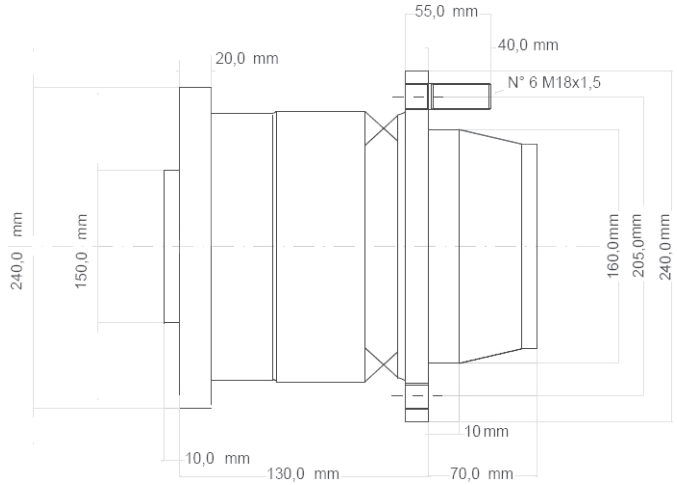

RADIAL LOAD

CARICO RADIALE

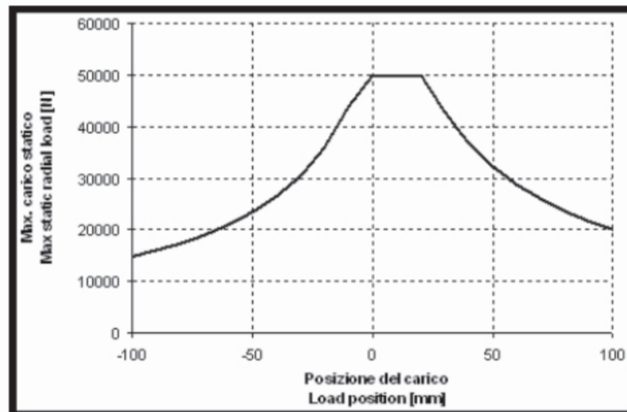

La posizione "0" coincide con la flangia ruota
Position "0" is coincident with wheel mounting

ORDER CODE

CODICE DI ORDINAZIONE

Wheel drive unit / *Riduttore tipo* S050 / B - - /GM05 /
ORB / Motor mounting flange / *Flangia motore*

Braking system / *Freno tipo* GM05
ORB

00 without brake / *senza freno*
01 static brake / *con Freno statico negativo*